

# AVALANCHE

Downhill Racing



**WOODIE**

**CHUBIE**

## PIGGYBACK

2.0 to 3.5" STROKE DOWNHILL  
MOUNTAIN BIKE SHOCK

# AVALANCHE

Downhill Racing

Avalanche Piggyback shocks have adjustable compression and rebound damping to allow you to fine tune your suspension for the increasing demands of today's downhill terrains. The shock is charged with a nitrogen and has adequate oil and N2 volume so you will not experience shock fade during a run. The shock features hard coat anodized aluminum CNC machined 30mm inside diameter body and a 12.5 mm diameter hard chrome steel shock shaft. The shock shaft is guided by low friction teflon coated bushings and a 5mm wide teflon piston ring keeping stiction to a minimum - while maintaining the necessary stiffness for the most demanding riders. The seals are high quality double wiper-type with a separate dust seal. This means you won't have to replace seals and bushings every week to get ready for the race. The shock has a heavy duty bumper anti-bottoming system to provide a soft cushion at the end of travel for those really big hits! The stainless steel shock bushings are provided with DU® sleeve bearings and dust seals for long life and reduced friction. The shock can also be revalved to suit the exact needs of your downhill riding style and ability.

# WOODIE

## Technical data

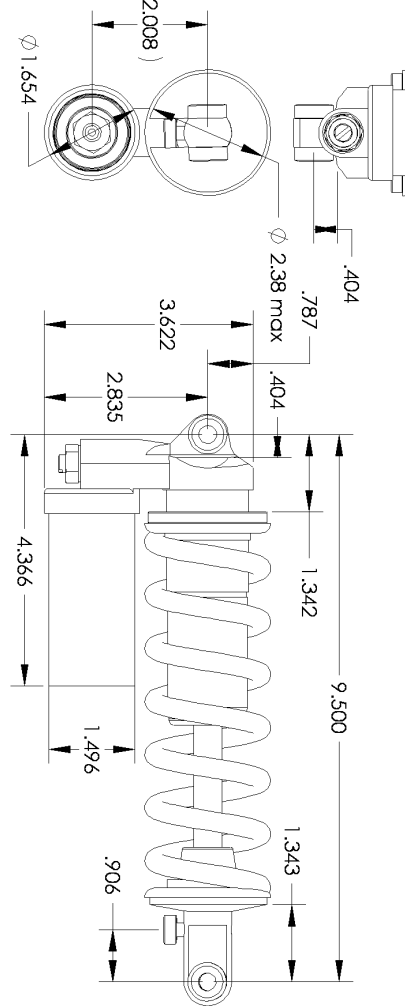

Woodie 7.5 x 2.25

## SPECIFICATIONS

SIZE.....	30mm dia
TRAVEL.....	2.0 to 3.5"
ADJUSTMENTS.....	16 clicks rebound 22 clicks low speed 3.25 turns high speed compression with optional adjuster threaded spring preload ad- justment with lock nut
MATERIAL.....	lightweight anodized 6061 T6 aluminum, hard chrome steel shaft
WEIGHT.....	2lbs 10 oz for 3.0 stroke
SPRING.....	350-800 lb/in coil
SEALS.....	double lip rubber with separate dust scraper
BEARINGS.....	DU® on Cres Bushings
EYE.....	7/16" dia x .500" wide
SHAFT BUMPER.....	19 mm heavy duty bumper
OIL.....	MX Shock Fluid
NITROGEN.....	160-285 psi, not adjustable
VALVING.....	fully revalvable
OPTIONS.....	alternate spring rates, Ti springs
TOOLS.....	12.5mm shaft clamp, Bladder removal tool nitrogen charging gauges and charging needle



## Technical data

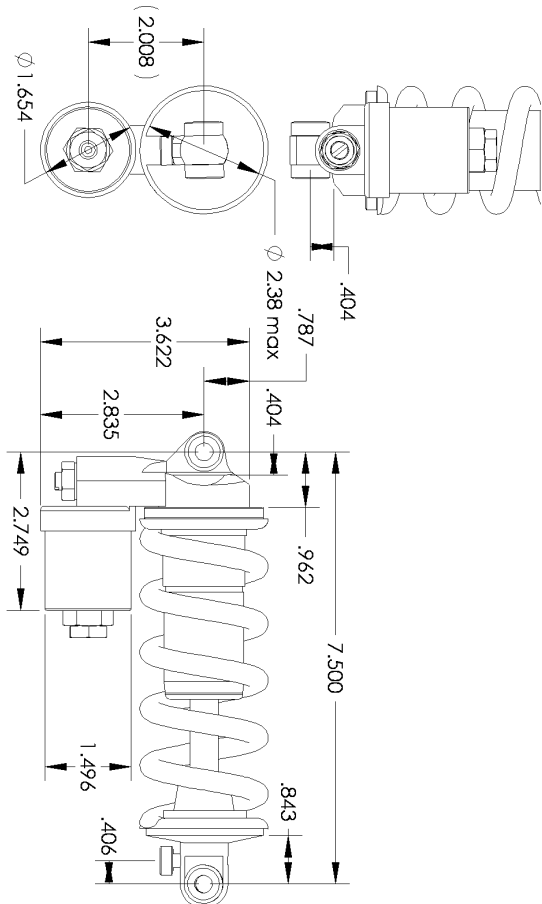

## Chubie 7.5 x 2.25 Set-up

The shock has an adjustable rebound and standard Hi/low compression. The optional independent hi/low compression adjuster has a low speed brass screw and a separate blue high speed hex. The rebound adjuster is at the bottom of the shock. The standard setting is 8 clicks out (counter clockwise) from full hard. To increase rebound damping turn the adjuster in (clockwise), this will slow the extension of the shock. To decrease rebound damping turn the adjuster out (counter clockwise) this will quicken the extension of the shock. The standard compression adjuster has a the slotted brass screw on the reservoir. The standard setting is 12 clicks out low/hi speed brass screw(counter clockwise) and 1.75 turns out on the blue hex high speed adjuster from full hard. To increase compression damping turn the adjuster in (clockwise) - this will stiffen the compression of the shock. The low speed compression adjuster will soften small bumps and improve traction. The optional high speed adjuster will firm up the damping for big hits with no loss in small bump compliance, firmer settings will improve pedaling as well, lighter settings will smooth out square edge hits. Spring preload can also be changed to tune the shock to the weight of the rider. The shock spring preload can be varied by tightening or loosening the preload collars. The standard preload is 1.5 turns, (min 1 turn / max 3 turns). The rider sag must be adjusted to 1/3 of the total stroke with the rider sitting on the bike. This is the difference from fully extended position to the rider sitting. The ride height can be raised or lowered  $\pm 5$  mm to quicken or slow steering within the range of preload settings.

## Add-on Features

The optional springs available are : 350 x 3.0, 450 x 3, 400 x 2.25, 500 x 2.25, 450 x 2.50, 550 x 2.75, 550 x 3.0, 600 x 2.25, 600 x 3.0, 650 x 2.75(Ti only), 700 x 2.25, 800 x 2.25 lb/in(Ti only).

The optional independent hi/low compression adjuster has a low speed brass screw and a separate blue high speed hex for independent fine tuning of the compression damping.

The features and quality contained in this shock were previously only found in an off road motorcycle suspension - but have been adapted to a mountain bike to give you the edge and reliability required for the increased speeds and jumps encountered on today's downhill runs. Experience the future in downhill mountain biking.

## Maintenance

The oil must be changed and nitrogen recharged every 60 hours or every 6 months whichever comes first.

*Its all downhill from here!*



## WARRANTY

*The set-up supplied with the shock has been adjusted for the rider weight, ability and terrain. The service, valving and set-up can be altered by Avalanche at the owners request within 60 days after the purchase date, free of charge. The shock is warranted for 1 year from date of purchase from defects and workmanship and will be repaired as required, free of charge. This warranty does not include damage caused by accident, wear and tear or abuse as determined by inspection by Avalanche. Avalanche shocks are for professional racing and the rider assumes all risks of injury while using this product.*

## Settings

ability \_\_\_\_\_ spring rate \_\_\_\_\_  
 terrain \_\_\_\_\_ nitrogen \_\_\_\_\_  
 weight \_\_\_\_\_ hi/low comp \_\_\_\_\_  
 hose \_\_\_\_\_ rebound \_\_\_\_\_  
 eye to eye \_\_\_\_\_ stroke \_\_\_\_\_

**AVALANCHE DOWNHILL RACING**  
**12 DAVIDSON ROAD**  
**COLCHESTER, CT 06415**  
**860-537-4306**  
**fax 860-537-8260**

website: [www.avalanchedownhillracing.com](http://www.avalanchedownhillracing.com)  
 e-mail: [support@avalanchedownhillracing.com](mailto:support@avalanchedownhillracing.com)