

AVALANCHE

SUSPENSION

AVA

ADVANTAGE

PROGRAM

Making suspension better for everyone.



Models Included:
Boxxer
Race/Team/World Cup
2006-2009 - 32 mm
2009-2010 - 35mm

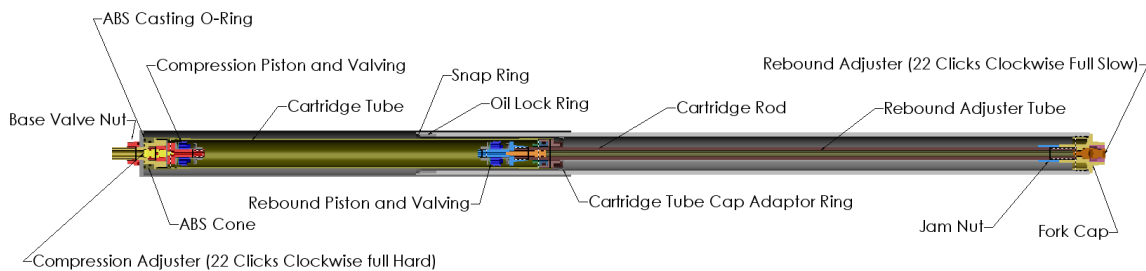

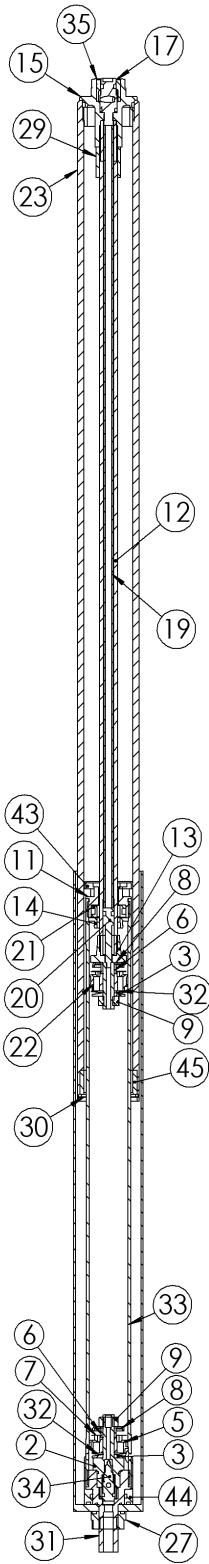

Materials List
32 mm Boxxer Cartridge Kit

ITEM NO.	QTY.	Description
2	1	comp arbor bolt
3	1	valve stop
5	1	20 comp piston
6	1	check spool
7	1	check valve
8	1	check valve cup
9	1	6 mm nut
11	1	cart tube end cap
12	1	cart rod
13	1	rebound stem
14	1	20 mm top out washer
15	1	fork cap boxxer
17	1	rebound adjuster
19	1	rebound adjuster rod
20	1	rebound needle
21	1	du bushing holder
22	1	20 rebound piston
23	1	Boxxer slider tube
27	1	Nut adapter
29	1	cart rod jam nut
30	1	31 mm snap ring
31	1	Comp bolt adapter 10mm
32	1	comp shims
33	1	cart tube
34	1	high low adj needle-1
35	1	adjuster detent THD
36	1	check valve cup
37	1	check spool
38	1	check valve
39	1	comp shims
40	1	valve stop
41	1	6 mm nut
42	1	boxxer casting dim
43	1	Cart tube end cap adaptor ring boxxer
44	1	abscone boxxer
45	1	Boxxer abs insert



Shown below for reference is the exploded view of the stock Boxxer Race/Team, use this in conjunction with the service manual provided by Rockshox to disassemble your fork to prepare it for the cartridge upgrade.

BOXXER RACE/TEAM - MOTION CONTROL w/ BLACK BOX SPEED STACK - 32mm (2006-2009)

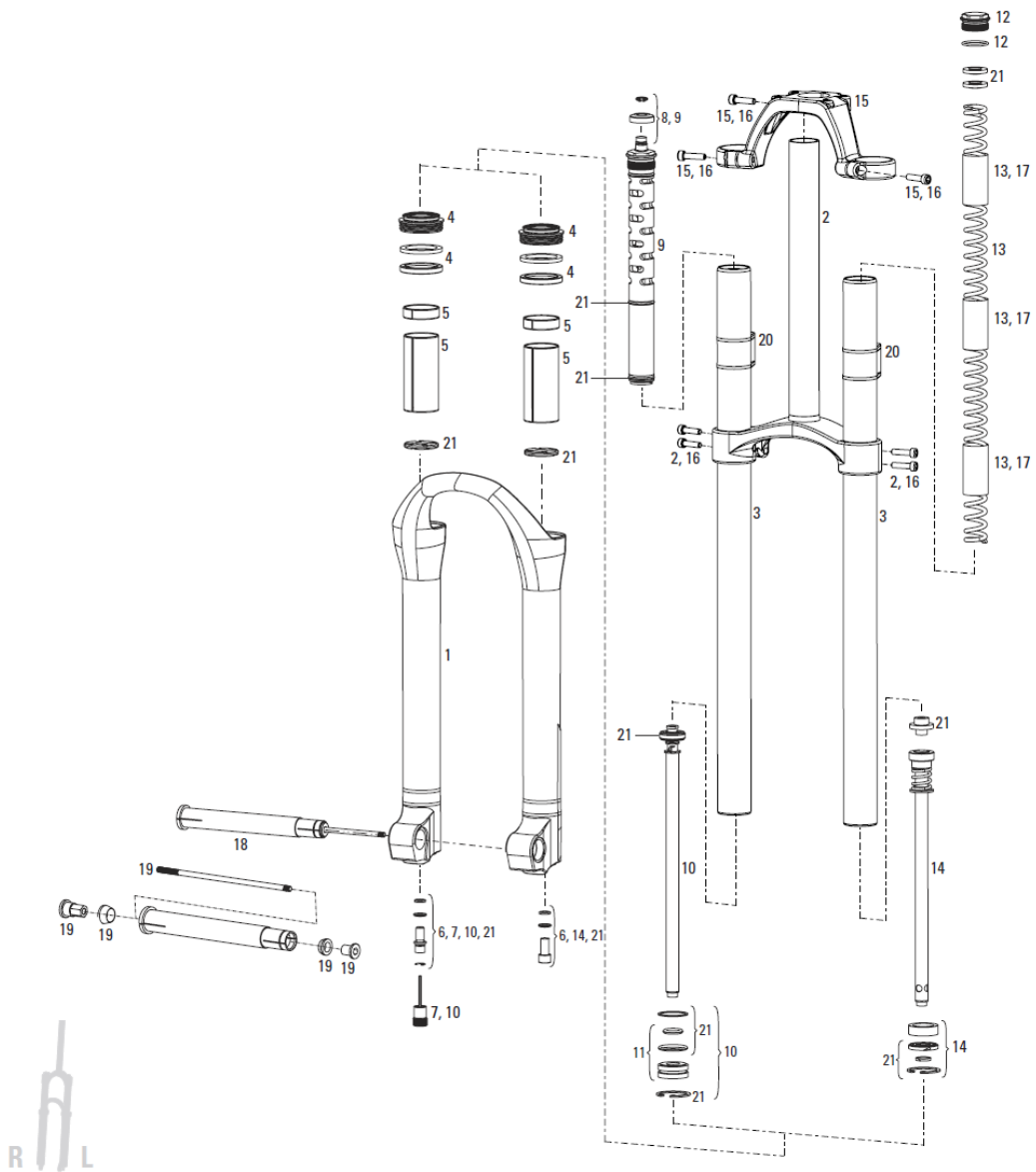

Note:

1. All service kits include any and all replaceable o-rings, retaining rings, crush washers, crush washer retainers, and shaft bolts/nuts. Air service kits include schrader valve(s).
2. Rebound damper and spring shaft kits include crush washers, crush washer retainers and shaft bolts, as well as upper tube retaining rings and rebound adjuster knob.
3. Damper side = rider's right. Spring side = rider's left.
4. All lower legs include bottom-out bumpers, bushings, foam rings and dust seals installed.
5. Lower leg includes Boxxer DH Maxle.
6. 06-09 Boxxer Race features Motion Control compression damper with fixed Floodgate setting. 06-09 Boxxer Team features Motion Control compression damper with adjustable external Floodgate adjustment.
7. Refer to the 2008 RockShox Technical Manual (www.sram.com) for oil volumes, air pressure settings and torque values.

Shown below for reference is the exploded view of the stock Boxxer World Cup, use this in conjunction with the service manual provided by Rockshox to disassemble your fork to prepare it for the cartridge upgrade.

BOXXER WORLD CUP - MOTION CONTROL w/ BLACK BOX SPEED STACK - 32mm (2006-2009)

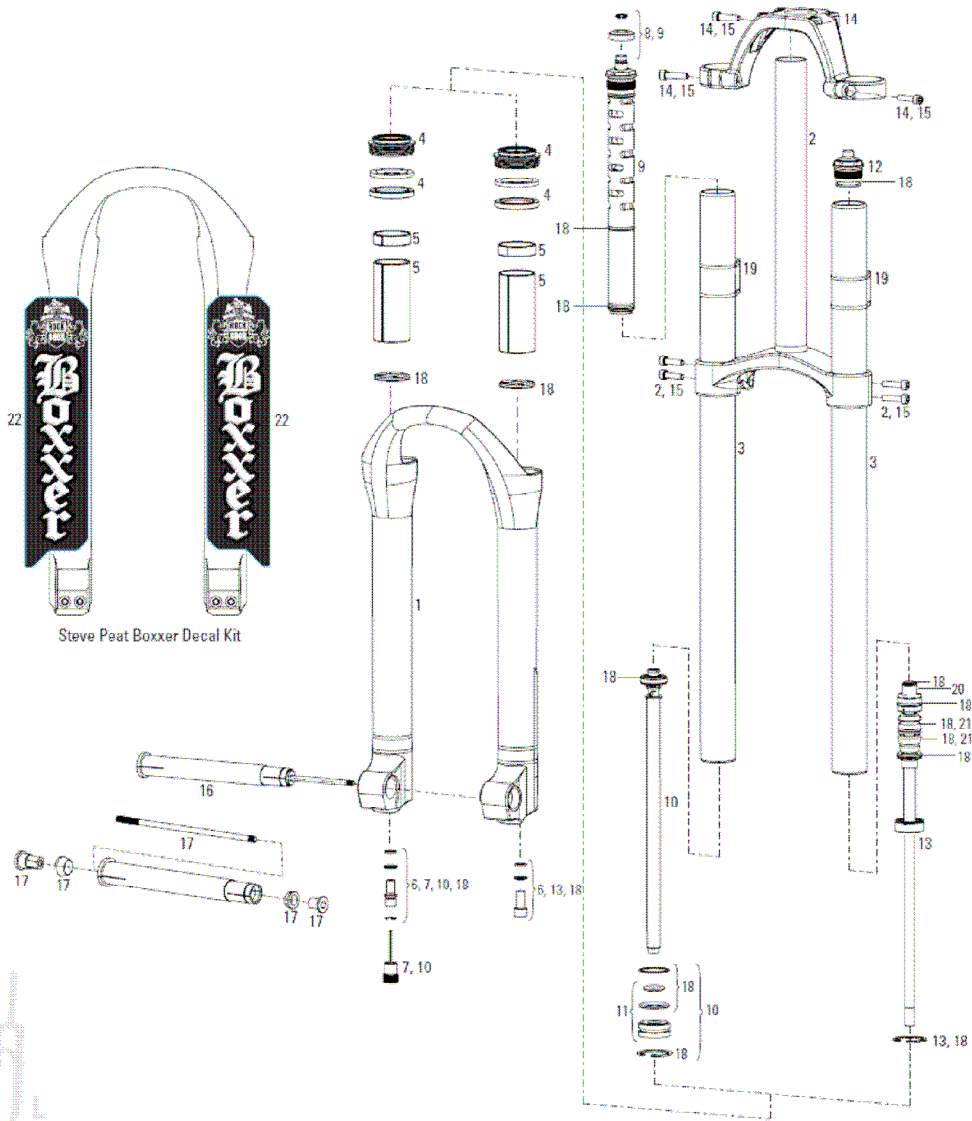

Note:

1. All service kits include any and all replaceable o-rings, retaining rings, crush washers, crush washer retainers, and shaft bolts/nuts. Air service kits include schrader valve(s).
2. Rebound damper and spring shaft kits include crush washers, crush washer retainers and shaft bolts, as well as upper tube retaining rings and rebound adjuster knob.
3. Damper side = rider's right. Spring side = rider's left.
4. All lower legs include bottom-out bumpers, bushings, foam rings and dust seals installed.
5. Lower leg includes Boxxer DH Maxle.
6. Boxxer World Cup (Solo Air) honed upper tube (spring side/rider's left) is required for use with Boxxer Solo Air spring assembly.
7. Refer to the 2008 RockShox Technical Manual (www.sram.com) for oil volumes, air pressure settings and torque values.

Shown below for reference is the exploded view of the stock 35 mm Boxxer Race, use this in conjunction with the service manual provided by Rockshox to disassemble your fork to prepare it for the cartridge upgrade.

BOXXER RACE - MOTION CONTROL IS - 35mm (2009-2010)

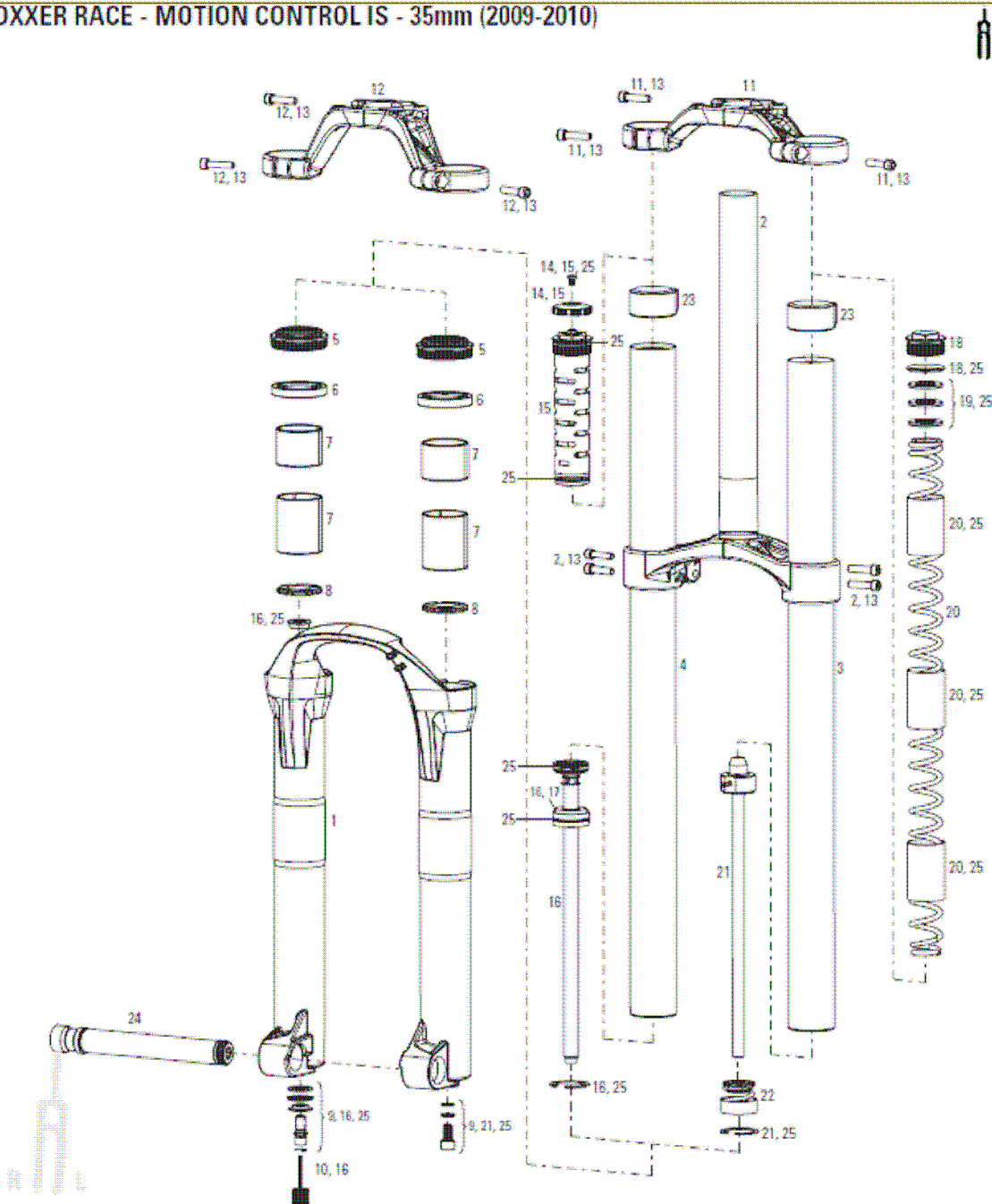

Note:

1. All service kits include any and all replaceable o-rings, retaining rings, crush washers, crush washer retainers, and shaft bolts/nuts.
2. Rebound damper and spring shaft kits include crush washers, crush washer retainers and shaft bolts, as well as upper tube retaining rings and rebound adjuster knob.
3. Damper side – Rider's right. Spring side – Rider's left.
4. All lower legs include decals, bottom-out bumpers, bushings, oil seals and dust seals installed.
5. All lower legs do not include Boxxer DR Maxle.
6. Boxxer Race lower leg is NOT compatible with Boxxer Team and World Cup. Boxxer Race lower leg includes an insert in the right/rebound shaft bolt hole to accommodate the Boxxer Race rebound damper steel shaft.
7. Refer to the 2010 Boxxer Race Technical Manual (www.sram.com) for oil volumes, air pressure settings and torque values.

Shown below for reference is the exploded view of the stock 35 mm Boxxer Team, use this in conjunction with the service manual provided by Rockshox to disassemble your fork to prepare it for the cartridge upgrade.

BOXXER TEAM - MISSION CONTROL DH - 35mm (2009-2010)

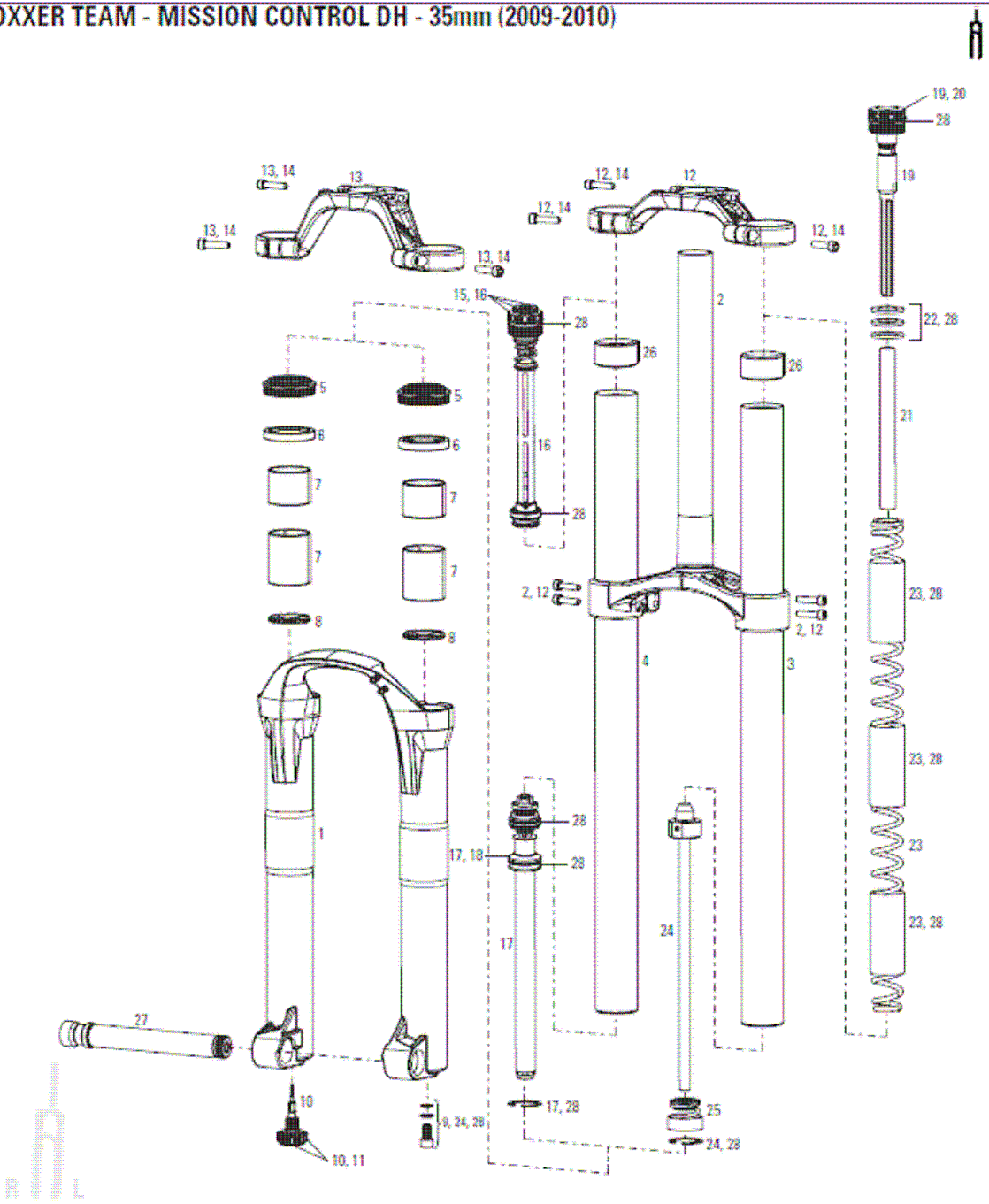

Note:

1. All service kits include any and all replaceable o-rings, retaining rings, crush washers, crush washer retainers, and shaft bolts/nuts.
2. Spring shaft kit includes crush washer, crush washer retainer and shaft bolt, as well as upper tube retaining ring.
3. Damper side - rider's right. Spring side - rider's left.
4. All lower legs include decals, bottom-out bumpers, bushings, oil seals and dust seals installed.
5. All lower legs do not include Boxxer DH Maxite.
6. Boxxer Race lower leg is NOT compatible with Boxxer Team and World Cup.
7. Refer to the 2010 BoXXer Team Technical Manual (www.sram.com) for oil volumes, air pressure settings and torque values.

Shown below for reference is the exploded view of the stock 35 mm Boxxer World Cup, use this in conjunction with the service manual provided by Rockshox to disassemble your fork to prepare it for the cartridge upgrade.

BOXXER WORLD CUP - MISSION CONTROL DH - 35mm (2009-2010)

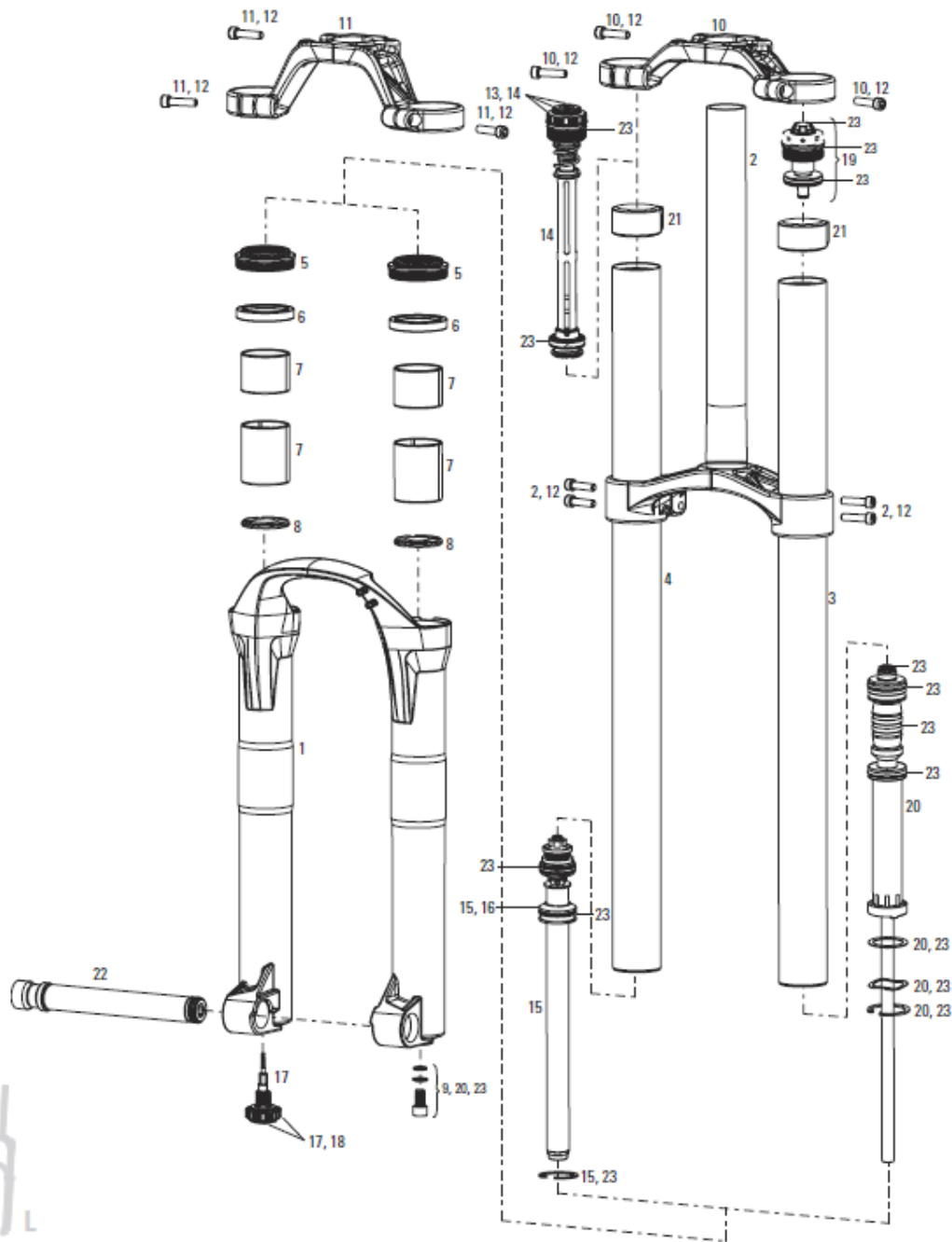

Note:

1. All service kits include any and all replaceable o-rings, retaining rings, crush washers, crush washer retainers, and shaft bolts/nuts. Air service kits include schrader valve(s).
2. Rebound damper and spring shaft kits include crush washers, crush washer retainers and shaft bolts, as well as upper tube retaining rings and rebound adjuster knob.
3. Damper side – rider's right. Spring side – rider's left.
4. All lower legs include decals, bottom-out bumpers, bushings, oil seals and dust seals installed.
5. All lower legs do not include Boxxer DH Maxle.
6. Boxxer Race lower leg is NOT compatible with Boxxer Team and World Cup.
7. Refer to the 2010 Boxxer World Cup Technical Manual (www.sram.com) for oil volumes, air pressure settings and torque values.

Preparing your Boxxer for the Avalanche Advantage Cartridge upgrade kit

The following steps will help guide you through the disassembly process and show you how to install the new cartridge:



For 32 mm Boxxers. Using a 4.5 mm allen key loosen the bolt 4-5 turns



Tap gently with a hammer to unseat the damper rod



Loosen the screw more if necessary and tap until the rod is unseated



Remove the bolt



For 35 mm Boxxer Team/World Cup remove rebound base bolt adjuster

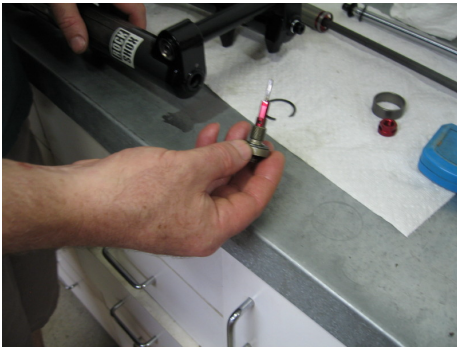

For 35 mm Boxxer Team/World Cup disassemble similar to above procedure



For 35 mm Boxxer Race disassemble similar to above procedure

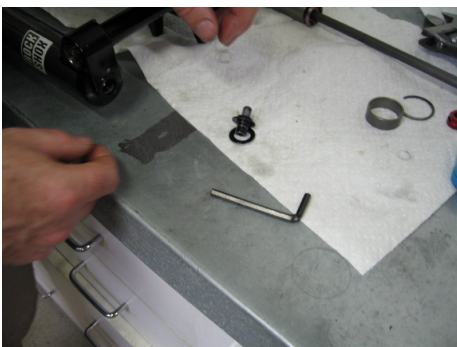

For 35 mm Boxxer Race a insert bushing must be removed to install the cartridge kit, it is difficult to see because the powder coat has covered it up and makes it look like part of the lower casting



For 35 mm Boxxer Race a insert bushing can be removed by using a socket that is slightly larger than the hole by tapping it with a hammer until it breaks free of the press fit and powder coat



For 35 mm Boxxer Race a insert bushing can be seen half way pressed out, continue tapping gently until it pops into the leg



For 35 mm Boxxer Race a insert bushing is shown removed here



For the 32 mm Boxxer pull the slider tube and damper rod from lower legs



assembly

For 35 mm Boxxer Race/Team/World Cup remove the upper slider



assembly

For 35 mm Boxxer Race remove the snap ring and rebound damper rod

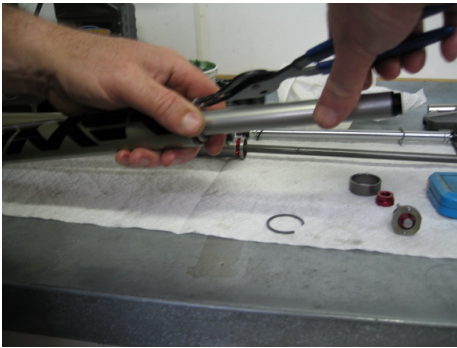

damper rod assembly

For 35 mm Boxxer Team/World Cup remove the snap ring and rebound



removed

For 35 mm Boxxer Team/World Cup rebound damper rod assembly shown



For 35 mm Boxxer Race rebound damper rod assembly shown removed



Insert a coat hanger or welding rod with a slight hook at the end



Reach to the bottom of the lower leg and hook the bottom out bumper



Remove the bottom out bumper and discard, this will not be used



For the 35 mm Boxxer the bottom out bumper shown being removed



For the 32mm Boxxer using snap ring pliers remove the ring from the bottom of the slider leg



For the 32mm Boxxer remove all the components so the slider bottom hole is empty



For the 32mm Boxxer reinsert the slider tube in the lower leg



the bottom of the leg

For the 32mm Boxxer push the slider tube all the way in until it contacts



mm hole extended thru (35 mm Boxxer does not require drilling)

For the 32mm Boxxer this end of the lower leg will need the internal 10



to avoid falling in

For the 32mm Boxxer drill with a 10 mm drill slowly blowing off the chips



For the 32mm Boxxer deburr the hole and remove any visible chips



remain in the tube

For the 32mm Boxxer remove the slider tube being careful that the chips



For the 32mm Boxxer clean the slider tube and lower leg of any remaining chips, flush if necessary



For the 32mm Boxxer insert the oil lock ring with the internal chamfer facing out/down so the oil lock ring can engage the bottom out cone smoothly



For the 32mm Boxxer insert the snap ring



For the 35 mm Boxxer install the oil lock ring with the chamfer facing out/down so the oil lock ring can engage the bottom out cone smoothly



For the 35 mm Boxxer insert the snap ring



Grease the oil and dust seals with your favorite slippery grease



Insert the slider tube shown in the 32 mm Boxxer



Insert the slider tube shown in the 35 mm Boxxer



Prepare the cartridge kit as shown, remove the fork cap



Use RTV or thick grease to help secure the -018(Boxxer 32)/ -019(Boxxer 35) o-ring to the bottom of the ABS cone



Inset the o-ring into the bottom groove

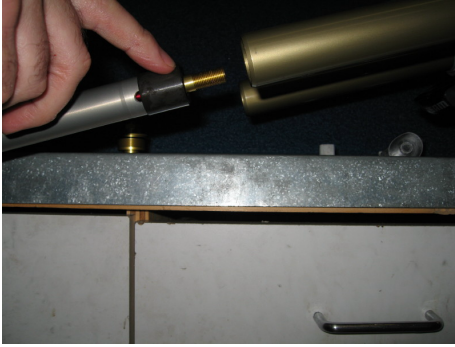

Insert the cartridge assembly into the slider/lower leg, take care to not knock off the base o-ring

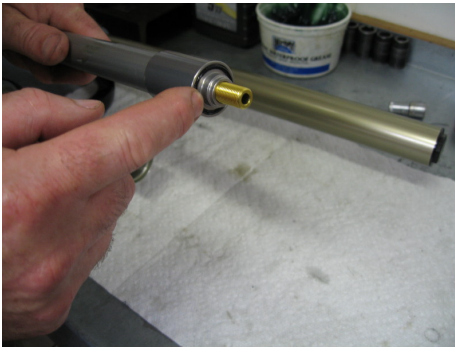

O-ring shown installed on the Boxxer 35 mm kit



Insert the cartridge assembly into the 35 mm slider/lower leg, take care to not knock off the base o-ring



Guide the cartridge assembly thru the entire slider tube



Line the 10 mm adaptor bolt to the lower hole



Push it thru until the ABS cone bottoms on the lower leg



Prepare the 10 mm adaptor nut with RTV to help secure the -014 o-ring



Thread the nut with the o-ring facing the lower leg



35 mm

Thread the nut with the o-ring facing the lower leg shown on the Boxxer



Tighten the nut to 10-15 in-lbs



Measure out 150 cc (standard amount Boxxer 32) / 225 cc (standard amount Boxxer 35) of cartridge fork oil 85/150 or equivalent



Pour oil into upper leg being careful not to spill any



Pour oil into upper leg being careful not to spill any shown in Boxxer 35



Cycle rod to remove any air bubbles and insert the rebound adjust rod



Screw on the fork cap



Make sure the fork cap bottoms on the cartridge rod before the jam nut



Bring the jam nut up to the fork cap and tighten with a slight squeeze on the two wrenches, approximately 10 in-lbs, be careful not to over tighten as these parts can easily be damaged



Screw on the fork cap



Tighten fork cap hand tight

The fork can now be reassembled with the crowns and installed on your frame as described by your owners manuals.

Adjustments and internal settings are described in more detail in the following pages. The fork cap adjuster is the low speed rebound and the standard setting is 12 clicks out (counterclockwise) from full hard. The 10 mm adaptor bolt contains the low speed compression adjuster and the standard setting is 12 clicks out (counterclockwise) from full hard. It can be turn by inserting a small (3.75 mm wide max) flat blade screwdriver up into the lower leg adaptor bolt.

Set-up Options:

Oil Type:

Recommended oil:

[Golden Spectro 85/150 Cartridge Fork Fluid 5wt or equivalent](#)

Pro Honda HP Fork Oil 5wt

Pro Circuit Fork Fluid PC-01

Yamalube 01 Suspension Oil / KYB 01

Bel-Ray Fork Fluid 5wt

There are many others that we have not tested but as long as they say for Cartridge Forks and or 85/150 rating they will work fine, all 5 wt fork oils are not the same so beware of lesser quality oils that may foam up easily

Oil height: Dry assembly:

Standard volume: 150 ml/cc - Boxxer 32 mm
225 ml/cc - Boxxer 35 mm

Optional Stiffer volume: 165 ml/cc - Boxxer 32 mm
250 ml/cc - Boxxer 35 mm

Optional Softer volume: 140 ml/ cc - Boxxer 32 mm
200 ml/cc - Boxxer 35 mm

Wet/already assembled: (Recommended, more accurate way)

Standard height from top fully compressed: 130 mm

Optional Stiffer height from top fully compressed: 115 mm – Boxxer 32 mm
95 mm – Boxxer 35 mm

Optional Softer height from top fully compressed: 140 mm – Boxxer 32 mm
160 mm – Boxxer 35 mm

Compression and Rebound Settings:

These are rough starting points, adjustments will vary from rider to rider

Standard:

Compression 12 clicks out from full clockwise

Rebound 12 clicks out from full clockwise

Downhill roots/rocky conditions:

Compression 17 clicks out from full clockwise

Rebound 15 clicks out from full clockwise

All Mountain smooth/drops conditions:

Compression 8 clicks out from full clockwise

Rebound 10 clicks out from full clockwise

Urban large drops to flat conditions:

Compression 5 clicks out from full clockwise

Rebound 8 clicks out from full clockwise

Revalving the Cartridge Kit:

For more details see above link to 20 mm Cartridge Revalving Procedure:

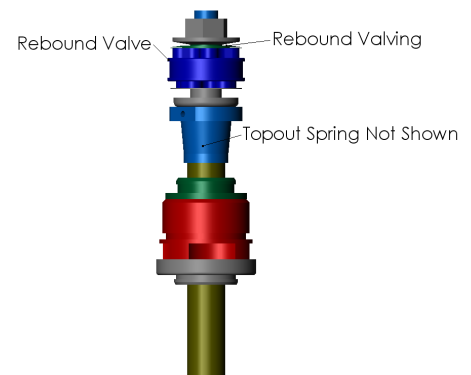
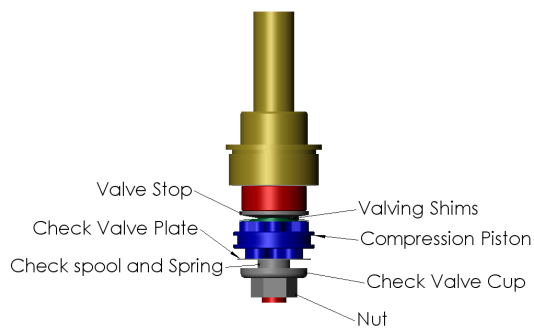

Standard Valving:
6mm ID Shims

Compression	Rebound
17x.10	17x.10
15x.10	11x.10
16x.10	9x.10
14x.10	16x.10
13x.10	14x.10
12x.10	12x.10
11x.10	10x.10
10x.10	8x.20
8x.20	

Optional Stiffer Compression/Slower Rebound Valving:

Compression	Rebound
17x.10	17x.10
16x.10	17x.10
15x.10	12x.10
14x.10	10x.10
13x.10	16x.10
12x.10	14x.10
11x.10	12x.10
10x.15	10x.10
8x.20	8x.20

Optional Softer Compression/Faster Rebound Valving:

Compression	Rebound
17x.10	17x.10
11x.10	10x.10
16x.10	8x.10
14x.10	15x.10
12x.10	13x.10
10x.10	11x.10
8x.20	9x.10
	8x.20

Disclaimer

Avalanche Suspension Inc. is not responsible for any damages to you or others from riding, transporting or other use of your Avalanche Advantage Rockshox Boxxer or mountain bike. User fully understands that mountain bike riding and/or racing is dangerous and hard on equipment. In the event your Avalanche Advantage Boxxer cartridge kit fork breaks or malfunctions, Avalanche Suspension Inc. will assume no liability or obligation beyond the repair or replacement of your fork.



12 Davidson Road, Colchester CT 06415-1600 USA

860-537-4306

www.avalanchedownhillracing.com